

## 1 General

Fan diameter Ø: 305 mm  
 Nominal voltage: 24 V  
 Drive family: SBL300P  
 Part number: 30107196

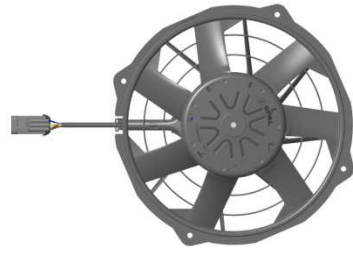

## 2 Features

Max fan speed	rpm	3100
Min fan speed	rpm	800
Sound pressure level at max speed	dBA	73 – at 1 m from the fan module - lateral side
Weight	kg	2.2
Operating supply voltage range	V	16.0 .. 32.0 at the Drive connector
Supply voltage to reach max speed	V	26.0 .. 32.0 at the Drive connector
Operating ambient temperature range	°C	-40 .. +120
Max operating ambient temperature @ max fan speed	°C	+95 (1)
Storage temperature range	°C	-40 .. +125
Lifetime	h	up to 40000 hours depending on mission profile
Time from 0 rpm to max speed	s	11
Load dump protection (Pulse 5b)	V	65 - Pulse peak voltage (U <sub>s</sub> *) - ISO16750-2:2010
Reverse polarity protection		ISO 16750-1 functional status class C - device fully functional after correcting the polarity
Notes: (1) Few minutes ambient temperature transients do not engage the derating owing to the thermal inertia of the system. Overloads may anticipate derating.		

### 3 Air performance at maximum speed

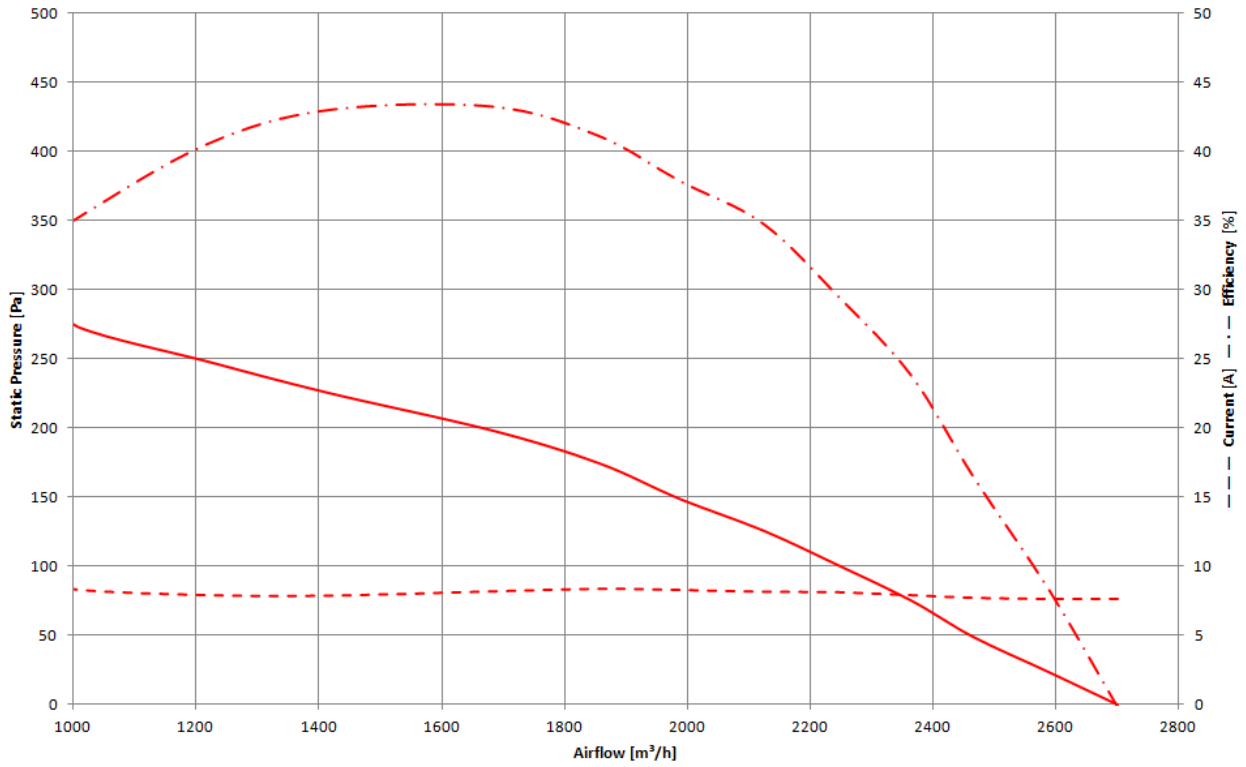

Air density 1.21 kg / m<sup>3</sup> - Test number: #14048 – Test bench compliant to ANSI AMCA 210  
TAMB = 20 °C ± 5 °C - UB = 26.0 V at the Drive connector

Any unauthorized use and / or copy of this document is strictly forbidden

#### 4 Mechanical data

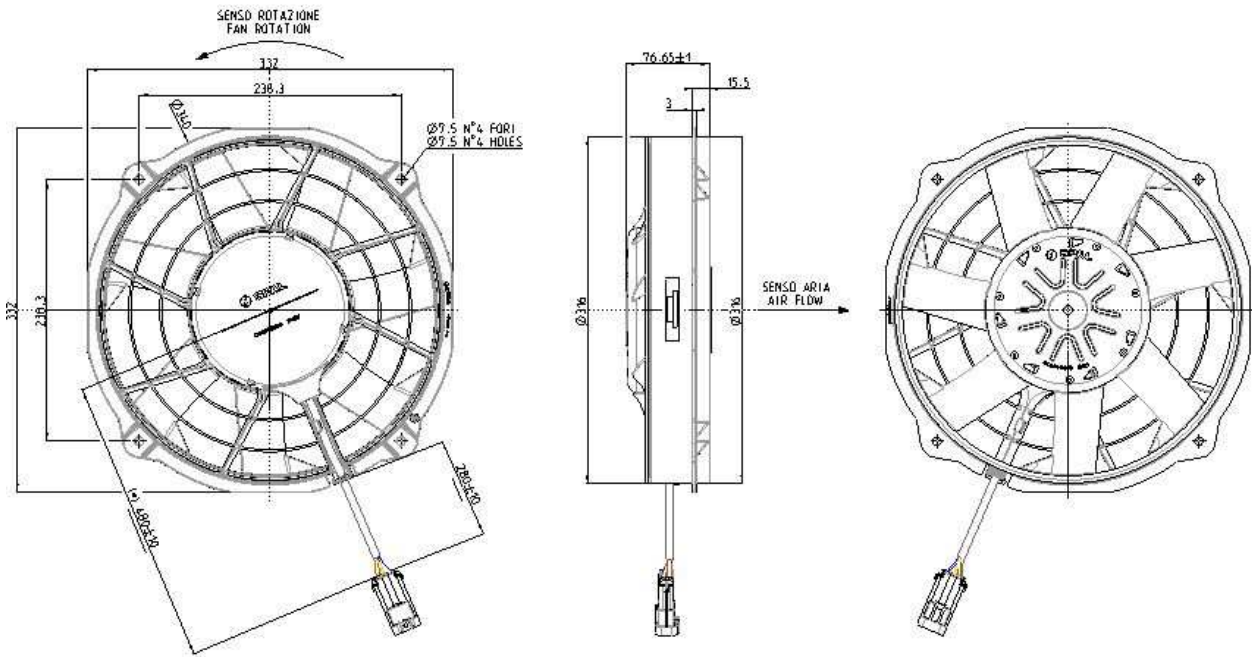

Fixing recommendation: use M6 bolts for fixing. Nominal tightening torque 5 +1/0 Nm  
Nominal torque defined for brand new, clean and lubricant-free bolts.

## 5 Connector and wires

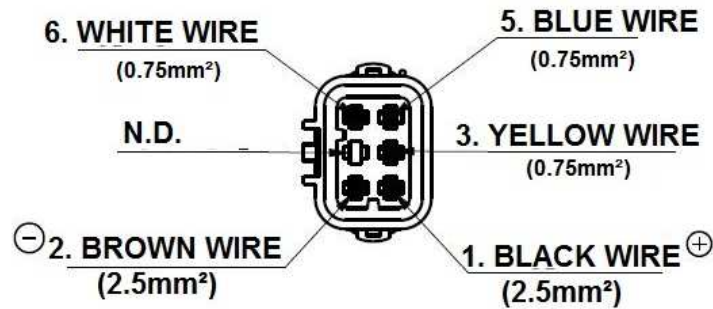

Connector part number : DELPHI 12185126						
Secondary lock part number : DELPHI 12185000						
Pin number	1	2	3	4	5	6
Identification	+D	-D	PWMA / E	N.D.	EI	FO
Wire Color	Black	Brown	Yellow	-	Blue	White
Sealing	15324973	15324973	15324974	10730124	15324974	15324974
Pin	12185237	12185237	12185129	-	12185129	12185129
Sect. [mm <sup>2</sup> ]	2.5	2.5	0.75	-	0.75	0.75

For abbreviations see chapter **8.2 Drive pin functions**

NOTE: Never handle the fan module via the cable harness

## 6 Further Features

Compliance		ECE Reg. 10-04 and updates - Automotive EMC directive. 2002/95/EC RoHS - Hazardous Substances 2000/53/EC and updates - End-of Life Vehicle
Ingress Protection		IP 68 and IP6K9K design
Allowed power supply max ripple	rms	1 % - contact SPAL for special needs
Fuse protection		An automotive fuse according ISO8820 must be chosen and used by the customer in the application wire harness. Each drive must be protected by the unique proper fuse (e.g. in case of double fan modules, two fuses are needed)

## 7 Measurement conditions

The below conditions are assumed:

- $T_{AMB} = 20\text{ °C} \pm 5\text{ °C}$  and
- Supply voltage **UB** = 26.0 V at the **Drive** connector

unless otherwise specified.

## 8 Hardware functions

### 8.1 Drive diagram

The Drive diagram is shown below.

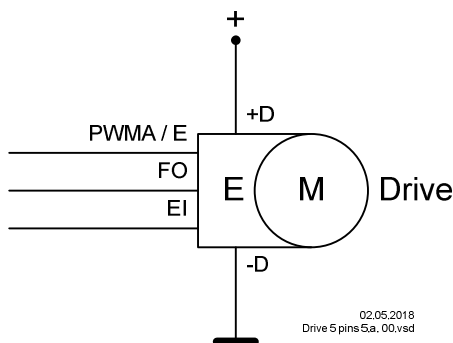

E stands for integrated electronics. M stands for motor. Drive stands for motor with axial integrated electronics.

### 8.2 Drive pin functions

The electrical Drive interface consists of 5 pins:

Power pins:

- supply voltage plus: +D
- supply voltage minus: -D

Signal pins:

1. Input: digital PWM input / active high: PWMA / E
2. Output: feedback output / active high: FO
3. Input: economy input / active high: EI

The signal pin PWMA / E and EI are used to control the Drive mode. PWMA / E it is the control input. PWMA / E can be a digital PWM active high signal or an Analog signal.

It is called digital PWMA input / active high because the signal processing of a PWM signal applied to the input PWMA / E is done in such a way that the PWM signal is filtered and then read with an analog input by the microcontroller of the Drive electronics. In this way also relatively high PWM base frequencies can be used (>100Hz).

*Any unauthorized use and / or copy of this document is strictly forbidden*

The signal pin FO is used to notify the Drive status.

### 8.3 Drive interface

The Drive interface, i.e. the connections between the CCU (Custom Control Unit) and the Drive, is depicted in the following picture.

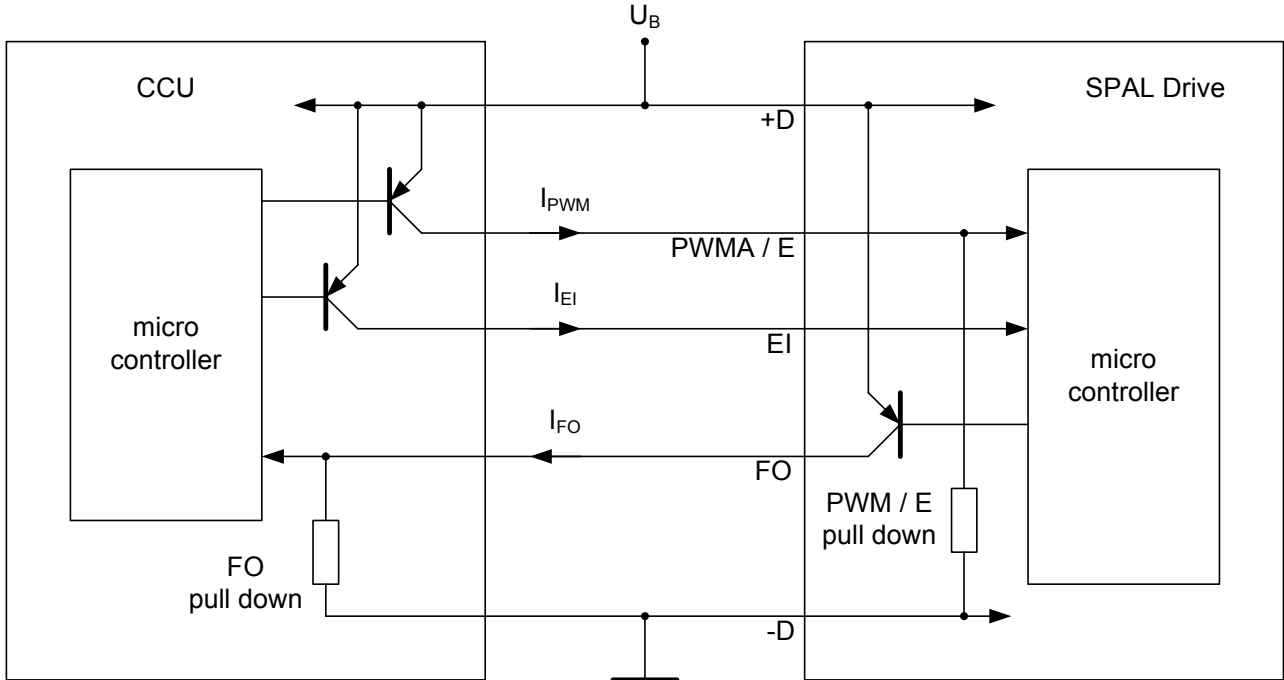

02.05.2018  
 5.a. 00.vsd

Connection with digital PWM signal active high

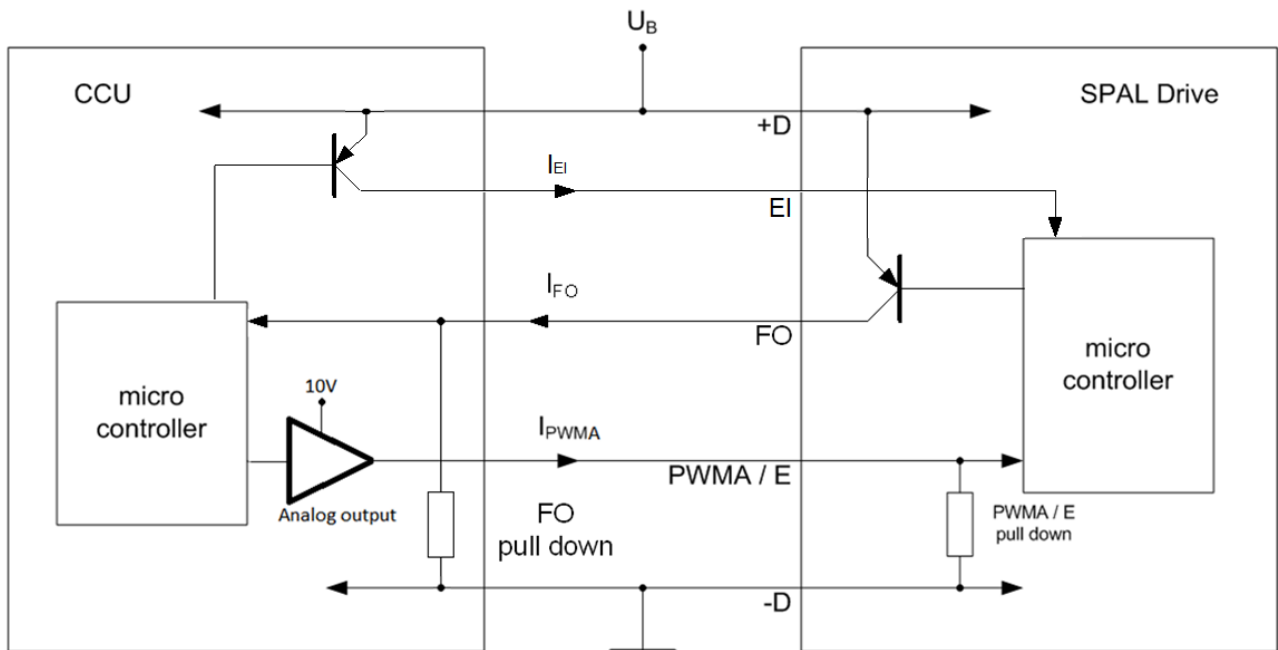

16.04.2018  
 4.G.02

Connection with Analog signal

*Any unauthorized use and / or copy of this document is strictly forbidden*

The CCU electronics and the Drive electronics are connected via three unidirectional lines.

The PWM signal for the input PWMA / E comes from the CCU electronics and uses a pull down resistor (PWMA / E pull down) located in the Drive electronics to determine the recessive level.

This pull down resistor is connected to the supply voltage minus: -D / GND.

The dominant level on the input PWMA / E is high level, provided by the switching to plus stage depicted in above figure as a bipolar pnp transistor in the CCU.

The signal for the input EI comes from the CCU electronics and uses a pull down resistor (EI pull down) located in the Drive electronics to determine the recessive level.

This pull down resistor is connected to the supply voltage minus: -D/ GND.

The dominant level on the input EI is high level, provided by the switching to plus stage depicted in above figure as a bipolar pnp transistor in the CCU.

The difference between the inputs PWMA / E and EI is the waking up function:

PWM / E is also waking up the Drive from Quiescent current mode.

EI is not waking up the Drive from Quiescent current mode.

This means to use the input EI also the input PWM / E must be on dominant level. Or in other words the input EI alone cannot be used.

The output FO comes from the Drive electronics and uses a pull down resistor (FO pull down) located in the CCU electronics.

The dominant level on output FO is high level, provided by the switching to high stage depicted in above figure as a bipolar pnp transistor in the Drive.

## 9 Interface hardware

### 9.1 Interface hardware for Digital control: pin PWMA / E

The input PWMA / E is used to wake up the Drive from Quiescent current mode. Any PWM duty cycle that guarantees a pulse going to the dominant level for more than  $T_{wakeup}$  will wake up the Drive electronics.

Parameters	Min	Typical	Max	Unit	Denomination
PWMA / E frequency range	50		50000	Hz	$f_{PWM}$ 3)
PWMA / E duty cycle range	0		100	%	$dc_{min} .. dc_{max}$ 4)
PWMA / E high level voltage	12			V	$U_{PWMH}$ 1)
PWMA / E low level voltage			1	V	$U_{PWML}$ 1)
PWMA / E resolution		$\pm 1$		%	$dc_{resol}$
PWMA / E accuracy		$\pm 3$		%	$dc_{accu}$
PWMA / E current	-10 %	0.45	+10 %	mA	$I_{PWMA}$
PWMA activation level	4	7	9	%	$dc_{Eact}$ 2)
PWMA / E leakage (quiescent) current			4	$\mu A$	
PWMA / E wake up voltage	1.4			V	$DC_{PWMA}$ 1)
PWMA / E duration for wakeup	150			$\mu s$	$T_{wakeup}$

1): the PWMA thresholds consider a temperature range of -40 °C to 120 °C in the electronics

2): the activation level  $dc_{Eact}$  considers a temperature range of -40 °C to 120 °C in the electronics

3): for SPAL production line internal reasons there is a test mode implemented which is activated at a PWM frequency range from 6 Hz to 20 Hz with dedicated duty cycles for various test modes.

The application must not use this frequency range!

4): for dc around the Min level the fan can be power-on or power-off, see  $dc_{Eact}$ . For dc more than Max level must consider the maximum speed

### 9.2 Analog control: pin PWMA / E

The input PWMA / E is used to wake up the Drive from Quiescent current mode. Any Analog signal that guarantees a voltage more than  $DC_{PWMA}$  will wake up the Drive electronics.

Parameters	Min	Typical	Max	Unit	Denomination
PWMA / E nominal voltage range	0		10	V	
PWMA / E current	-10 %	0.25	+10 %	mA	$I_{PWMA}$ at 10V
PWMA / E absolute maximum voltage	-32		35	V	

*Any unauthorized use and / or copy of this document is strictly forbidden*

Parameters	Min	Typical	Max	Unit	Denomination
PWMA / E leakage (quiescent) current			4	$\mu\text{A}$	
PWMA / E wake up voltage	1.4			V	DC <sub>PWMA 1)</sub>

1): the PWMA thresholds consider a temperature range of -40 °C to 120 °C in the electronics

### 9.3 EI: economy input / active high

Parameters	Min	Typical	Max	Unit	Denomination
EI- high level input voltage	8.8		36	V	$U_{EIH}$
EI- low level input voltage			4.0	V	$U_{EIL}$
EI- active high: max current	0.27		1.22	mA	$I_{EI}$
EI- impedance		29.5 $\pm$ 10%		K $\Omega$	
EI- speed		1800 $\pm$ 5%		rpm	

### 9.4 FO: feedback output / active high

Parameters	Min	Typical	Max	Unit	Denomination
FO voltage	$U_B - 2 \text{ V}$		$U_B$	V	$U_{FO}$
FO current			50	mA	$I_{FO}$



## 10 Software functions

### 10.1 Drive modes

The Drive has different working modes related mainly to the Drive current consumption:

1. Quiescent current mode
2. Electronics active mode
3. Run mode
4. Failure mode

The Drive mode changes accordingly to the control input duty cycle on pin PWMA / E and the voltage level on the same input.

No.	Drive mode	Current consumption	Drive speed	FO
1	Quiescent current mode	< 100 $\mu$ A	0	Recessive
2	Electronics active mode	< 40 mA	0	Recessive
3	Run mode	depending on the requested speed and on the load	depending on the PWM duty cycle or the analog input voltage level	Recessive
4	Failure mode	< 40 mA	depending on the failure	Dominant

The Quiescent current mode is entered when the pin PWMA / E is on 0 % duty cycle (recessive level) and the voltage level is 0V. The time to go into Quiescent current mode depends on the actual PWM base frequency and the number of samples for the plausibility check (see chapter 11.3). Additionally 2 s are waited after the detection of the absence of the PWM signal before finally going into Quiescent current mode. The Electronics active mode is entered with any PWM duty cycle value between 0 % and < 100 % if the condition from chapter 10 is fulfilled ( $T_{wakeUp}$ ) or the voltage level is greater of 0V.

The Run mode is entered in the following cases:

- if the PWM duty cycle on pin PWMA / E has a value where the Drive is asked to run (see chapter 11.2)
- if the analog signal on pin analog input PWMA / E has a value where the Drive is asked to run (see chapter 11.4).

The Failure mode is entered in case of failures of the Drive (see chapter 11.5).

### 10.2 Digital control: transfer function PWM input

The transfer function PWM input is the relation between the Drive speed and the duty cycle on the pin digital PWMA input / active high: PWMA / E.

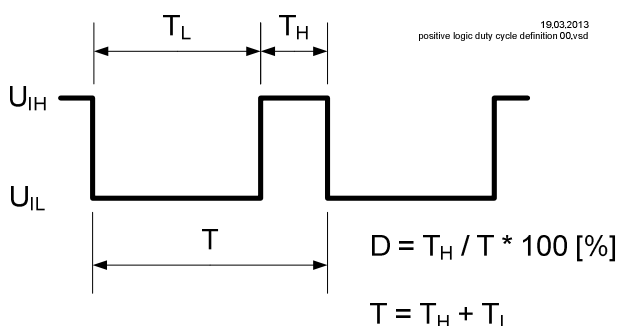

It is called "positive logic duty cycle definition".

Considering this definition,

- continuous low voltage is 0 % duty cycle (recessive level)
- continuous high voltage is 100 % duty cycle (dominant level)

Based on this duty cycle definition the transfer function PWM input is shown in the following figure.

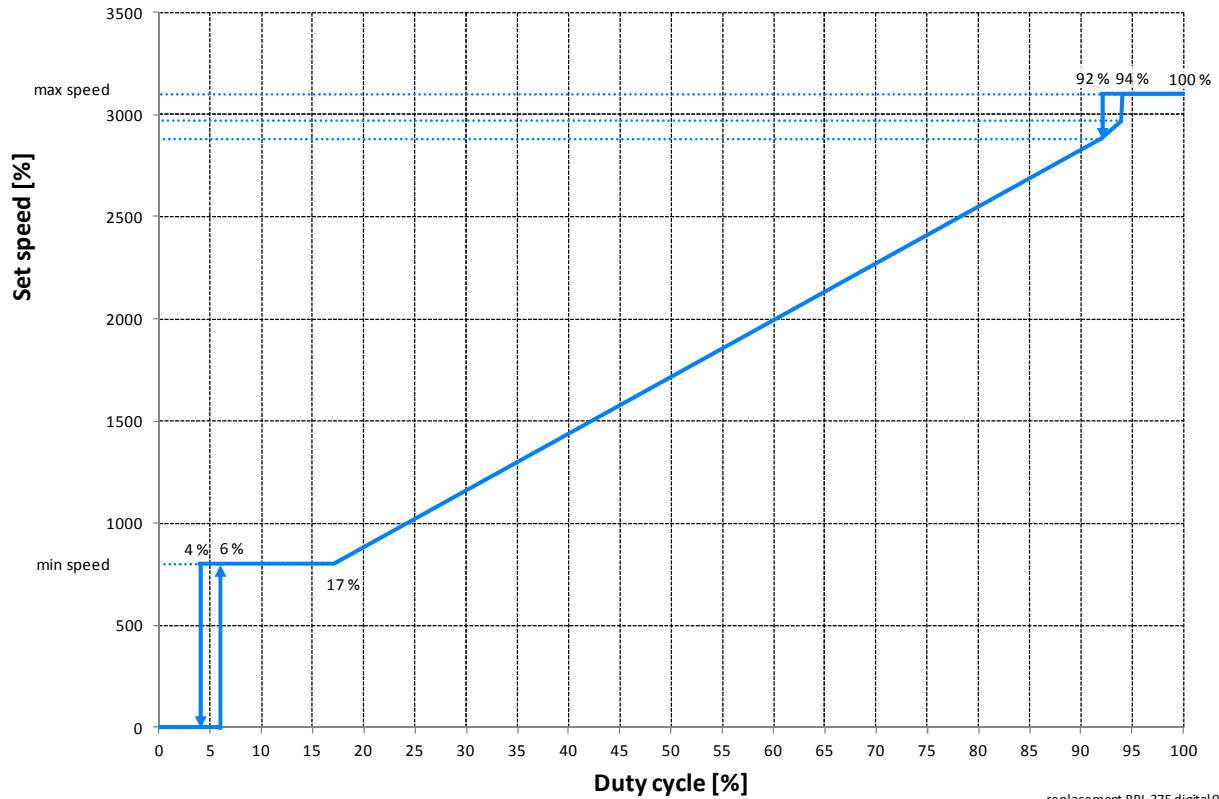

replacement BBL 375 digital 000.xlsm

### 10.3 Analog control: transfer function analog input

The transfer function analog input is the relation between the Drive speed and the voltage on the pin PWMA/E (see following figure).

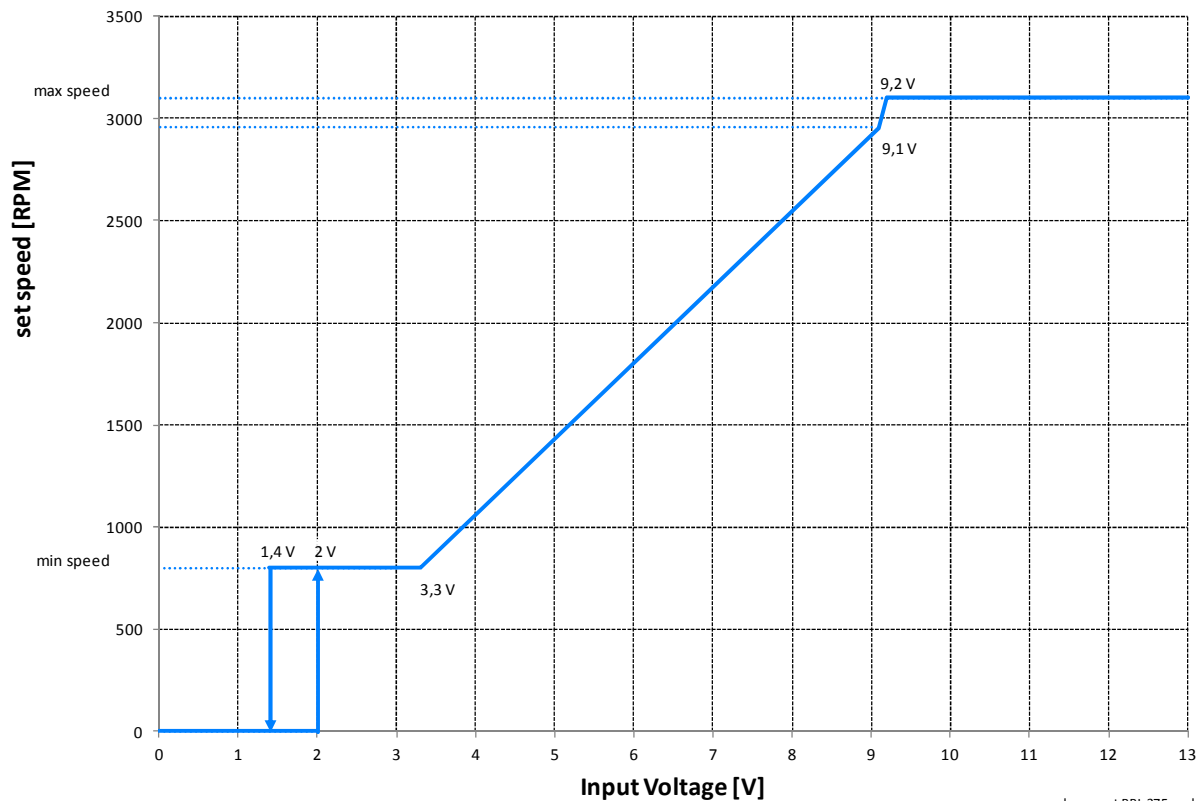

replacement BBL 375 analog 000.xlsm

NOTE: tolerance on voltage threshold for minimum speed is  $2 \pm 0.5$  V

Any unauthorized use and / or copy of this document is strictly forbidden

### 10.4 Drive speed set point with Digital control

The PWM signal on the control input PWMA / E is measured by the Drive electronics. The PWM signal applied to the input PWMA / E is done in such a way that the PWM signal is filtered and then read with an analog input by the microcontroller of the Drive electronics.

### 10.5 Relation between PWMA / E and EI

In above table the Relation between PWM / E and EI can be found:

PWM / E	EI	Drive mode	Comment
recessive level	recessive level	Quiescent current mode	
recessive level	dominant level	Quiescent current mode	Current flows into the input EI
PWM > $dc_{Eact}$	recessive level	Run mode / Electronics active mode	Drive follows PWM request
PWM > $dc_{Eact}$	dominant level	Run mode / Electronics active mode	Drive goes to economy speed

For the definition of recessive and dominant see chapter 10 and 11.2.  
 The economy speed is ~58 % of the max speed.

### 10.6 Drive mode Failure modes

There are the following cases where the Drive will go into Failure mode and stop the Drive:

Failure modes	Handling of the failure	Notification
Drive blocked	In case of detection of a rotor locked the following strategy is used: a delay of 3 s till the next start attempt is introduced. If this start attempt fails again a delay increased by further 3 s till the next start attempt is introduced. This delay increase is repeated till the delay between the attempts is 30 s after which no further attempts are made.	FO is set to dominant level
Drive overloaded	Fan speed is reduced in case of overload detection by means of current draw measurement.	FO set to recessive
Over current	In case of detection of a rotor locked the following strategy is used: a delay of 3 s till the next start attempt is introduced. If this start attempt fails again a delay increased by further 3 s till the next start attempt is introduced. This delay increase is repeated till the delay between the attempts is 30 s after which no further attempts are made.	FO is set to dominant level
Drive overheated	Fan speed is reduced in case of overheating detection (derating). Over the max operating temperature, the Drive will stop.	Over the max operating temperature FO is set to recessive level
Under and Over voltage	If the supply voltage is outside the specified range the Drive will stop.	FO set to recessive
Internal Drive failure	The Drive will stop if a failure is detected during the startup self check procedure.	FO is set to dominant level

In all cases the Drive tries to recover from failures when a valid PWM signal is detected which asks the Drive to run.

## 11 Units and acronyms

Unit		Physical Quantity	Prefix	Dimension	
%	percent	Proportionality	M	10 <sup>6</sup>	mega
Ω	Ohm	Electrical Resistance	k	10 <sup>3</sup>	kilo
°C	degree Celsius	Temperature	m	10 <sup>-3</sup>	milli
A	Ampere	Current	μ	10 <sup>-6</sup>	micro
h	hours	Time	n	10 <sup>-9</sup>	nano
dBA	deciBel (A-weighting)	Sound pressure level	p	10 <sup>-12</sup>	pico
Hz	Hertz	Frequency			
min	minute	Time			
Pa	Pascal	Pressure			
rpm	Revolutions per minute	Rotation frequency			
s	second	Time			
V	Volt	Voltage			
W	Watt	Power			

**Table 1: Units of measurements**

Key Word	Description
AMPL_IN	Amplitude PWM input signal
CCU	Custom Control Unit
Drive	Motor with axially integrated electronics
IGN	Ignition (KL15)
PWM	Pulse Width Modulation
R <sub>i</sub>	Input Resistance
SBL	Sealed brushless
T	Temperature
T <sub>AMB</sub>	Ambient Temperature
U <sub>B</sub>	Supply voltage
U <sub>n</sub>	Nominal supply Voltage
rms	root mean square

## 12 Document change history

Initial document author: document author  
 Latest revision: 000

Document author	Date	Revision	Comment
SPAL TEAM	02.0'5.2018	000	Initial Version.

**Table 2: Document change history**

Document status: released

*Any unauthorized use and / or copy of this document is strictly forbidden*

<b>1</b>	<b>General</b> .....	<b>1</b>
<b>2</b>	<b>Features</b> .....	<b>1</b>
<b>3</b>	<b>Air performance at maximum speed</b> .....	<b>2</b>
<b>4</b>	<b>Mechanical data</b> .....	<b>3</b>
<b>5</b>	<b>Connector and wires</b> .....	<b>4</b>
<b>6</b>	<b>Further Features</b> .....	<b>5</b>
<b>7</b>	<b>Measurement conditions</b> .....	<b>5</b>
<b>8</b>	<b>Hardware functions</b> .....	<b>5</b>
8.1	Drive diagram .....	5
8.2	Drive pin functions .....	5
8.3	Drive interface .....	6
<b>9</b>	<b>Interface hardware</b> .....	<b>7</b>
9.1	Interface hardware for Digital control: pin PWMA / E .....	7
9.2	Analog control: pin PWMA / E .....	7
9.3	EI: economy input / active high .....	8
9.4	FO: feedback output / active high .....	8
<b>10</b>	<b>Software functions</b> .....	<b>9</b>
10.1	Drive modes .....	9
10.2	Digital control: transfer function PWM input .....	9
10.3	Analog control: transfer function analog input .....	10
10.4	Drive speed set point with Digital control .....	11
10.5	Relation between PWMA / E and EI .....	11
10.6	Drive mode Failure modes .....	11
<b>11</b>	<b>Units and acronyms</b> .....	<b>12</b>
<b>12</b>	<b>Document change history</b> .....	<b>12</b>